



Biosense Webster
a *Johnson & Johnson* company

COOLFLOW™ IRRIGATION PUMP USER MANUAL



© 2001 Biosense Webster, Inc.
All rights reserved.

Biosense Webster, Inc.
3333 Diamond Canyon Road
Diamond Bar, CA 91765, USA
Tel: +1-909-839-8500
Tel: +1-800-729-9010
Fax: +1-909-468-2905
www.biosensewebster.com

Biosense Webster
Johnson & Johnson Medical NV/SA
Dreve Richelle 161 Building H
B-1410 Waterloo, Belgium
Tel: +32-2-352-1411
Fax: +32-2-352-1592

COOLFLOW™ is a trademark of Biosense Webster, Inc.
Caution: Federal (U.S.A.) law restricts this device to sale by or on the order of a physician.

Manual P/N: M-5276-323A

COOLFLOW™ Irrigation Pump

User Manual – English

TABLE OF CONTENTS

1. Device Description	1-3
Unpacking the Pump.....	1-3
Electrical Connections	1-4
2. Safety Information	1-4
Intended Use / Indications	1-4
Warnings.....	1-4
Precautions.....	1-5
3. Setting Up the COOLFLOW Pump	1-6
IV Pole Mount	1-6
Turning the Pump On.....	1-7
Loading the Tubing Set in the Pump.....	1-7
Preparing for Irrigation	1-9
4. Working with the Control Panel	1-9
5. Using the Foot Pedal (optional)	1-11
6. Alarms and Error Codes	1-11
7. Preventive Maintenance / Service	1-13
Cleaning.....	1-13
Preventive Maintenance	1-13
Calibration/Adjustments	1-13
Storage	1-13
8. Specifications	1-14
EMC Information.....	1-15
9. Accessories	1-19
10. Limited Warranty & Limitation of Liability	1-20

LIST OF FIGURES & TABLES

Figure 1: The COOLFLOW Irrigation Pump.	1-3
Figure 2: Front view of the COOLFLOW Pump.	1-6
Figure 3: Rear view of the COOLFLOW Pump.....	1-7
Figure 4: Loading the tubing set in the pump.	1-8
Figure 5: Close-up of the COOLFLOW pump control panel.....	1-9
Figure 6: The optional Foot Pedal used with the COOLFLOW Pump.	1-11
Table 1: Alarms and Error Codes, and the appropriate action.....	1-12
Table 2: Electromagnetic emissions	1-15
Table 3: Electromagnetic immunity	1-16
Table 4: Electromagnetic immunity	1-17
Table 5: Recommended separation distances between portable and mobile RF communications equipment and the COOLFLOW Irrigation Pump	1-18

1. DEVICE DESCRIPTION

The COOLFLOW™ Irrigation Pump is a peristaltic pump designed for the delivery of irrigation solutions when used in conjunction with the COOLFLOW Tubing Set and a ThermoCool® Catheter. The pump has a dual rate feature for one-touch irrigation rate change between a low flow rate (1-5 ml/min) and a high flow rate (5-30 ml/min). A large LED display indicates the flow rate selected. An optional foot pedal can be used to initiate high flow irrigation.

Figure 1:
The COOLFLOW
Irrigation Pump.

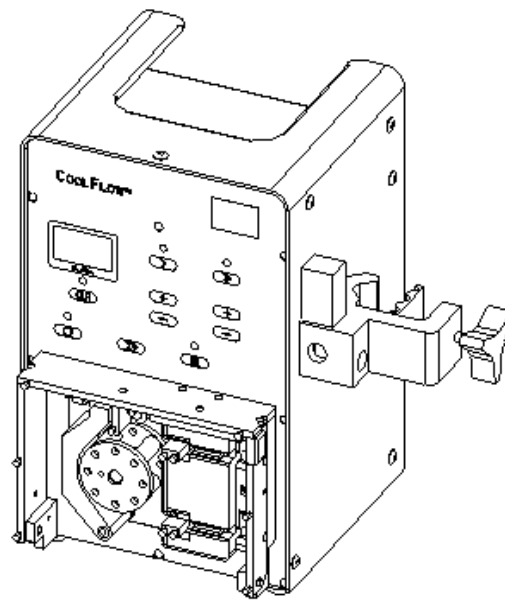

A transparent door protects the rotating head, while allowing visibility of the entire tubing set during pump operation.

Dual air-in-line detectors are employed for added safety in preventing air infusion. Audible alarms warn of air in the tubing, an open door, or operational errors.

A removable side-mounted pole clamp is included for mounting the pump to an IV pole or a horizontal mounting rail.

Unpacking the Pump

Remove the pump and power cord from the shipping container. Inspect the pump. If the pump has been damaged during shipping, please contact your nearest Biosense Webster Sales or Customer Service representative.

Electrical Connections

The pump operates using line power of 100 to 240V~, 50 to 60Hz. Connect only to a properly grounded 3-wire hospital grade power receptacle. The pump is not battery powered and cannot be used as portable equipment.

2. SAFETY INFORMATION

Intended Use / Indications

The COOLFLOW™ Irrigation Pump and Tubing Set is a peristaltic irrigation pump designed for the delivery of saline solution when used in conjunction with the Stockert 70 RF Generator and the ThermoCool™ Irrigation Catheter.

Warnings

- The COOLFLOW Pump is designed for use with only the Biosense Webster COOLFLOW Tubing Set only. Use of inappropriate tubing may cause improper operation of the pump and can result in improper irrigation.
- The COOLFLOW Pump is designed to stop the flow of irrigation solution when an alarm is activated. All alarms must be attended to immediately to ensure continued irrigation.
- The COOLFLOW Pump is designed for use with the ThermoCool catheter and the Stockert 70 Generator, which can detect hazard conditions caused by insufficient irrigation flow to the catheter tip. Flow can be verified visually by noting the drip rate in the drip chamber. Hospital personnel are responsible for verifying and monitoring the flow rate delivered to prevent under-infusion of irrigation fluid.
- Hospital personnel are responsible for monitoring the total saline load delivered to the patient to prevent over-infusion of irrigation fluid.
- Hospital personnel are responsible for verifying the proper performance of the pump and the compatibility of the solutions and irrigation devices used as part of the overall irrigation management. The COOLFLOW Pump and Tubing Set are designed for use with standard irrigation solutions such as normal saline. Specified flow rate accuracy may not be maintained when used with incompatible fluids or delivery devices.
- The COOLFLOW Irrigation Pump should not be used adjacent to or stacked with other equipment. If adjacent or stacked use is necessary, observe the COOLFLOW Irrigation Pump to verify normal operation in the configuration in which it will be used.

Precautions

- To avoid the possibility of biological contamination, and to ensure proper performance, do not reuse or resterilize the COOLFLOW™ Tubing Set. The tubing set is intended for single use only.
- Positive displacement irrigation pumps such as the COOLFLOW Pump should not be ported together with other infusion systems, including gravity fed IV infusion systems.
- To avoid the risk of explosion, do not use the pump in the presence of flammable anesthetics.
- To avoid the risk of electrical shock and fire, do not expose the pump to excessive moisture.
- External high-energy radio frequency interference (RFI) and electromagnetic radiation (EMR) can cause false alarms or compromised performance in electrical equipment such as the COOLFLOW Pump. In addition, electrical equipment such as the pump can occasionally induce artifacts on ECG monitoring systems that are not operating under optimal conditions. Although the pump has been designed to prevent such interference, safe operation should be verified prior to patient use when used in conjunction with RF electro-surgical equipment, electromagnetic navigation systems and ECG monitoring equipment. If interference occurs, reposition the pump.
- The pump has no user-serviceable components.
- The pump is calibrated by the manufacturer. Alteration of pump settings will cause improper operation and result in cancellation of the warranty.
- Moving parts such as the transparent door, pole clamp and rotating pump head, while designed for safe operation, should be operated with care.

3. SETTING UP THE COOLFLOW PUMP

Figures 2 and 3 provide front and rear view details of the COOLFLOW™ Pump, respectively.

IV Pole Mount

The pump can be mounted on a standard IV pole or a horizontal mounting rail using the removable pole clamp (#1 in Figure 2).

To install the pole mount:

1. Securely clamp the pole clamp onto the IV pole or mounting rail near the patient.
2. Slide the mounting post into the pole clamp. Make sure that the pole is stable prior to use.

NOTES

- It is recommended that a 5-legged hospital grade IV pole be used.
- To ensure stability, the pump should not be mounted higher than 135 cm above the base of the pole.

Figure 2:
Front view of the
COOLFLOW Pump.

- 1) Pole clamp
- 2) Door latch
- 3) Pump Head
- 4) Control Panel
- 5) LED display

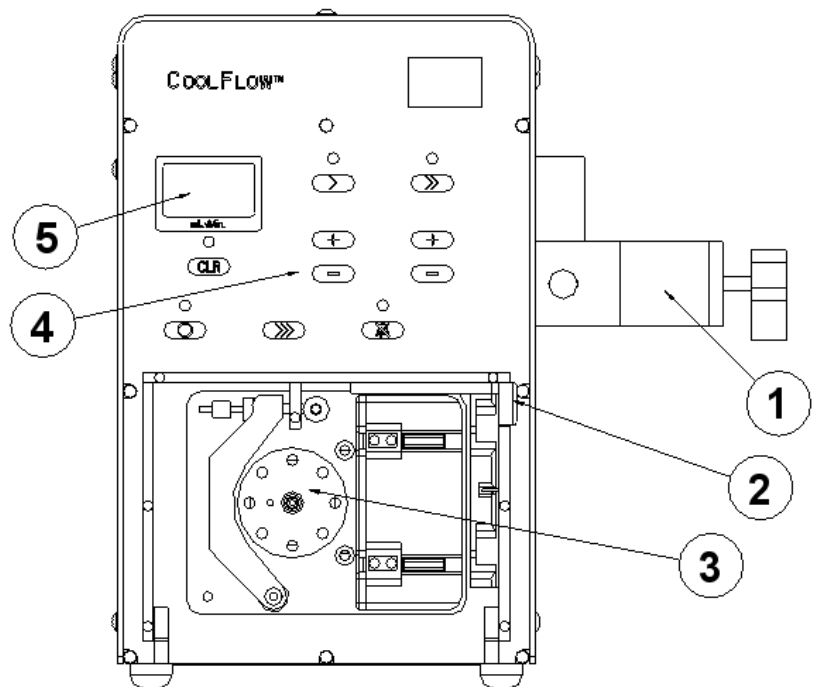

Turning the Pump On

The power switch (# 7 in Figure 3) is located on the back panel near the power cord inlet.

Once turned on, the pump performs a self-test and you will hear a short beeping tone. Once the self-test has passed, you will hear the tone again and the display will indicate a flow rate of 0 ml/min.

Figure 3:
Rear view of the
COOLFLOW Pump.
 6) AC power inlet
 7) Power switch
 8) Foot pedal
 connector
 9) Alternate pedal
 connector
 10) Ground Stud

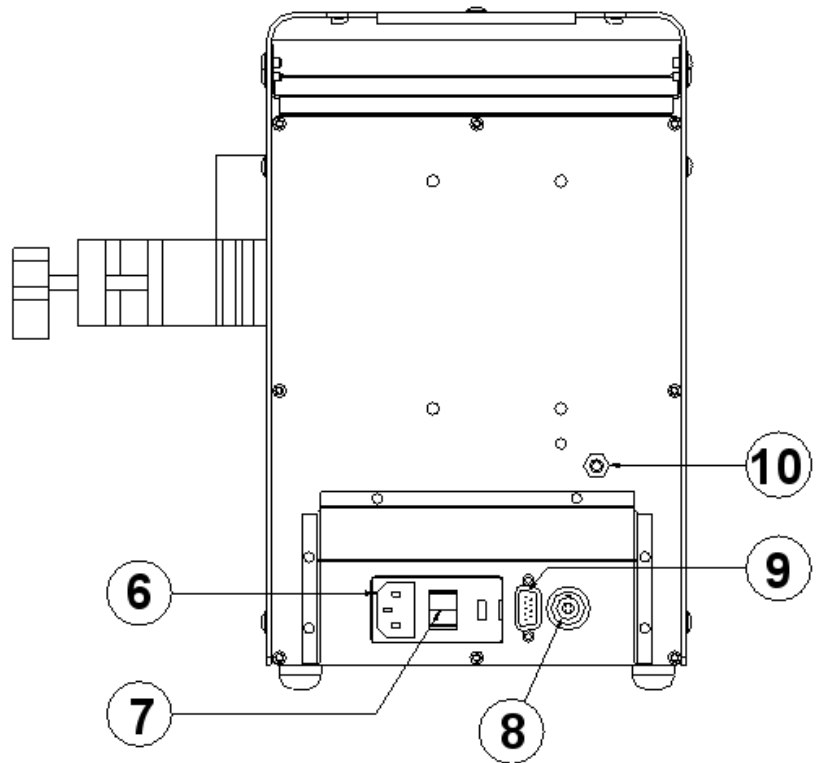

Loading the Tubing Set in the Pump

NOTE

Use only the Biosense Webster COOLFLOW™ Tubing Set.

To load the COOLFLOW Tubing Set in the pump (refer to Figure 4):

1. Connect the COOLFLOW Tubing Set to the IV solution container using standard safe hospital practices.
 - A new tubing set must be used for every procedure.

Do not reuse the tubing set.
2. Connect a stopcock to the patient end of the tubing set.

3. Open the stopcock and fill the tubing set with irrigation fluid. Remove any trapped air and then close the stopcock.

Figure 4:
Loading the tubing set
in the pump.
 See text for details.

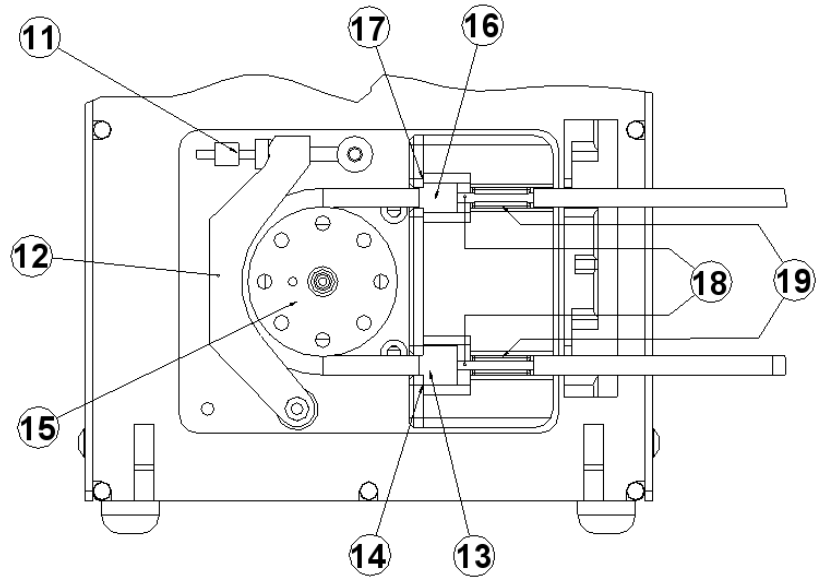

4. Hang the IV solution container near the pump, and fill the drip chamber about 2/3 full.
5. Open the door of the pump and release the spring arm (11) from the pressure plate (12).
6. Install the Large Tubing Stop (13) of the tubing set into the Lower Tubing Retainer (14). Note: the pump rotates in a clockwise direction.
7. Lay the tubing over the rollers on the left side of the pump head (15).
8. Gently stretch the tubing and place the Small Tubing Stop (16) of the tubing set into the Upper Tubing Retainer (17). Do not twist the tubing.
9. Place the smaller diameter tubing sections (18) fully into each Air-In-Line Detector (19).
 - To ensure proper operation of the Air-In-Line Detectors, the outer surface of the tubing must be dry.
10. Close the pressure plate and latch the spring arm.
 - Closing the pressure plate prevents free flow of fluids through the tubing set.
11. Close the transparent door of the pump.

Preparing for Irrigation

To prepare for irrigation:

1. Open the stopcock on the end of the tubing set.
2. Press and hold the Flush button (☞☞☞) to verify tubing integrity.
 - If you see any air in the tubing, hold down on the Flush button until the air is expelled through the open end of the tubing.
3. Securely connect the tubing to the ThermoCool Catheter.

The COOLFLOW™ Irrigation Pump is now ready for use.

4. WORKING WITH THE CONTROL PANEL

The control panel, located on the front of the pump, is used to set and display the flow rate, and to control pump operation. A close-up of the control panel is shown in Figure 5.

Figure 5:
Close-up of the
COOLFLOW pump
control panel.

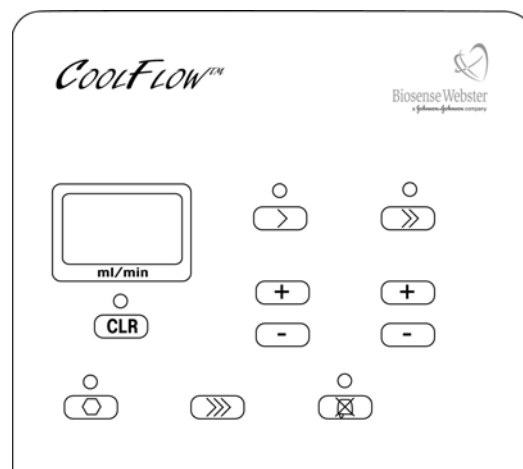

Use of the controls is detailed below.

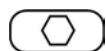

Stop button: Press to Stop rotation of the pump head. The pump will beep once to indicate that flow has stopped.

Press the **Low Flow** or **High Flow** button to restart the flow.



Flush button: Press to flush the tubing set. A flow of 60 ml/min is initiated and continues until the button is released. **Detection of air in the tubing is disabled during this process.**

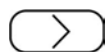

Low Flow button: Press to initiate flow at the preset low flow rate. The pump beeps once when the low flow rate begins. The default low flow rate is 2 ml/min.

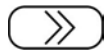

High Flow button: Press to initiate flow at the preset high flow rate. The pump beeps twice when the high flow rate begins. The default high flow rate is 30 ml/min.

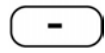
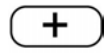

Increase (+)/Decrease (-) buttons: There are two sets of Increase/Decrease buttons, one set under the **Low Flow** button, the other under the **High Flow** button. Press the “+” or “-” button to increase or decrease the respective flow rate by 1 ml/min.

When adjusting the high or low flow rate, the LED display temporarily indicates the new setting for the associated flow rate, regardless of the current flow rate of the pump.

The new setting remains in effect until it is changed, or the pump is turned off.



Alarm Silence button: When an error is detected by the pump, the error code appears on the LED display and an audible alarm is heard. Press this button to silence the audible alarm for 2 minutes. The error code remains displayed until the Clear Error button is pressed (see below).



Clear Error button: Once an error has been corrected, press and hold the CLR button for 1 second to clear the error from the display. The pump returns to normal operating mode.

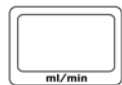

LED Display: The two-digit seven-segment LED display indicates the flow rate of the pump in ml/min. The actual flow rate is dependent on the tubing set integrity and fluid back pressure. When the pump is stopped, 0 ml/min is indicated.

When an error is detected the error code is displayed until that error has been cleared. Once the error is corrected (see **Section 6: Alarms and Error Codes**), use the Clear Error button (see above) to return to normal operation.

When adjusting the flow rate, the new setting for the associated flow rate is briefly displayed, regardless of the current flow rate of the pump.

For example: If the pump is currently running at a low flow rate of 2 ml/min and the high flow rate setting is changed, the new high flow rate setting is momentarily displayed.

5. USING THE FOOT PEDAL (OPTIONAL)

The foot pedal may be used to momentarily initiate a high flow rate.

To connect the foot pedal to the pump:

1. Place the Redel connector of the COOLFLOW™ Pedal (Figure 6) in the socket at the back of the pump (#8 in Figure 3).
 - The foot pedal is ready for use immediately upon connection.
2. An additional foot pedal connector (#9 - ‘D’ shaped 9-pin) is also provided on the back panel. For further details about this feature, contact your Biosense Webster representative, or refer to the COOLFLOW Irrigation Pump Service Manual, available from Biosense Webster.

To initiate the high flow rate with the pedal set:

1. Check that the pump is stopped, or running at a low flow rate.
2. Press and hold on the foot pedal.
 - You will hear two beeps indicating initiation of the high flow rate.
 - High flow is maintained while the pedal is held down.
3. To stop the high flow rate, release the foot pedal.
 - You will hear one beep indicating a return to the low flow rate.

Figure 6:
The optional Foot Pedal used with the COOLFLOW Pump.

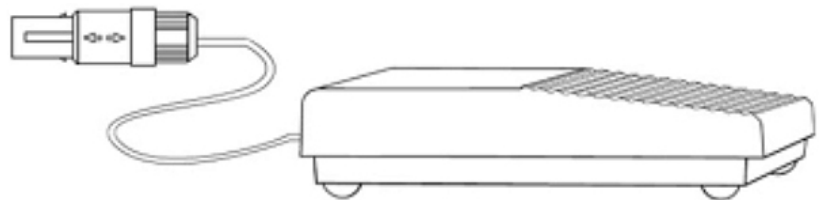

6. ALARMS AND ERROR CODES

When an error occurs or an alarm is activated, an audible warning is heard. The associated error/alarm code is shown in the LED display and the pump is stopped (exception: see “Air Bubble Detected” below).

The audible alarm can be temporarily silenced by pressing the “Alarm Silence” button. The code remains displayed and the audible alarm returns after 2 minutes.

To clear an alarm or error, press and hold the “CLR” button for 1 second. The pump will remain stopped and return to the normal operating mode.

A list of alarm and error codes, with the appropriate course of action is provided in Table 1.

Table 1: Alarms and Error Codes, and the appropriate action.

Codes are listed in alphabetical order.

Code	Alarm/Error Type	Action
bF	Bubble Detector Self Test Failure: Periodic self test of the air-in-line sensors has failed.	<ul style="list-style-type: none"> ➤ Turn power off and on again. ➤ If the failure occurs repeatedly, contact your local Biosense Webster Sales or Customer Service representative.
Blinking Flow Rate (in LED display)	High Flow Rate Time Reminder: The pump has been operating at a high flow rate for more than 6 minutes.	<ul style="list-style-type: none"> ➤ Press the Silence Alarm button to stop the audible alarm for 2 minutes. <p>Or</p> <ul style="list-style-type: none"> ➤ Switch to the low flow rate.
bu	Air Bubble Detected: Air was detected in the tubing by one of the air-in-line sensors. The pump will continue to rotate for 3 seconds before stopping, to briefly ensure continued irrigation while any associated equipment is turned off or removed from the patient.	<ul style="list-style-type: none"> ➤ Examine the tubing for trapped air. ➤ Remove the patient line from the patient and use the Flush button to purge air from the system. ➤ Check that the tubing is properly seated in the Air-in-Line detectors. ➤ Check for wet or dirty tubing in the Air-in-Line detectors. ➤ Check for damaged or blocked tubing.
Ch	Self Test: A hardware self-test is in progress.	<ul style="list-style-type: none"> ➤ If Ch remains displayed for more than one minute, the system failed one or more self-tests on power up. ➤ If the test fails repeatedly, contact your local Biosense Webster Sales or Customer Service representative
do	Door Open: The door is open during pump operation.	<ul style="list-style-type: none"> ➤ Close the door and verify that the door latch is securely fastened.
Fo	Foot Pedal: Communication with the Foot Pedal has been lost during high flow operation.	<ul style="list-style-type: none"> ➤ Check that the Foot Pedal plug is securely connected to the pump.
Pr	Internal Processor Error: An internal error has been detected in the micro controller or one of its supporting components.	<ul style="list-style-type: none"> ➤ Contact your local Biosense Webster Sales or Customer Service representative.
r1	Rotation Velocity Error: The pump head rotation speed was not as expected.	<ul style="list-style-type: none"> ➤ Check for improper installation of the tubing set.
r2	Reverse Rotation Error: Reverse pump head rotation was briefly detected.	<ul style="list-style-type: none"> ➤ Check for improper installation of the tubing set.

7. PREVENTIVE MAINTENANCE / SERVICE

Cleaning

The pump can be wiped clean with a damp cloth using standard hospital practices. Prior to cleaning the pump, be sure to disconnect it from the AC power supply. In addition:

- The pump head and pressure plate should be wiped clean after each use.
- Do not immerse the pump in any liquid, or expose the pump to steam autoclave or ethylene oxide (EO) sterilization.
- Do not expose the pump to excessive moisture, especially when AC power is connected.

Preventive Maintenance

It is recommended that periodic inspections be performed annually. Verification of the flow rate accuracy should be performed every six months.

Detailed instructions for performing the inspection and testing can be found in the COOLFLOW™ Irrigation Pump Service Manual, available from Biosense Webster. Inspections should be performed by qualified personnel only.

Calibration/Adjustments

There are no user serviceable components in the pump. The pump is calibrated by the manufacturer. Improper operation or damage to the pump can occur if altered by unauthorized personnel.

Storage

Disconnect AC power prior to long-term storage. Check that the pump door is closed when the pump is not in use.

Store the pump within the environmental conditions recommended for operation.

8. SPECIFICATIONS

The COOLFLOW™ Irrigation Pump is classified as Class I type CF ordinary equipment for continuous use, as defined by International Standard EN60601-1.

The Foot Switch is classified as IPX8 equipment for continuous immersion, as defined by International Standard IEC529.

The COOLFLOW Irrigation Pump complies with the following standards:

- EN60601-1/1988
- EN60601-1-2/2001
- UL2601-1
- CAN/CSA 22.2 No. 601.1/M90
- EN60601-2-24/1998 (applicable parts)

AC power requirements	100 - 240V~, 50/60Hz, 45VA grounded 3-wire hospital grade outlet. Use 2A 250V fuses.
Environmental conditions	(operating)
Temperature	10°C to 40°C
Relative Humidity	20% to 90%, non-condensing
Flow rate range (low range)	1 to 5 ml/min, 1 ml/min increments
Flow rate range (high range)	5 to 30 ml/min, 1 ml/min increments
Flush flow rate	60 ml/min
Maximum operating back pressure	35 PSI (2,4 atm) @ 30 ml/min
Maximum pressure generated	<100 PSI (6,8 atm)
Flow rate accuracy	-5% / +10% (6-30ml/min) -10% / +20% (1-5 ml/min,)
Minimum detectable bubble size	2 micro liters
Dimensions	
Height	30 cm
Width	21 cm (without pole clamp attached)
Depth	24 cm
Weight	7 kg
Power cord	3 m

EMC Information

The COOLFLOW™ Irrigation Pump complies to the requirements for electromagnetic compatibility (EMC) for medical devices as defined in IEC 60601-1-2:2001. To help the user ensure optimum operation, the following tables indicate the acceptable electromagnetic environment for operating the COOLFLOW Irrigation Pump.

Use of accessories other than those specified may result in increased emissions or decreased immunity of the equipment. Use only Biosense Webster accessories approved for use with the COOLFLOW Irrigation Pump.

Table 2: Electromagnetic emissions

ELECTROMAGNETIC EMISSIONS		
The COOLFLOW Irrigation Pump is intended for use in the electromagnetic environment specified below. The customer or the user of the COOLFLOW Irrigation Pump should assure that it is used in such an environment.		
Emissions test	Compliance	Electromagnetic environment – guidance
RF emissions CISPR 11	Group 1	The COOLFLOW Irrigation Pump uses RF energy only for its internal function. Therefore, its RF emissions are very low and are not likely to cause any interference in nearby electronic equipment.
RF emissions CISPR 11	Class A	The COOLFLOW Irrigation Pump is suitable for use in all establishments other than domestic and those directly connected to the public low-voltage power supply network that supplies buildings used for domestic purposes.
Harmonic emissions IEC 61000-3-2	Class A	
Voltage fluctuations/flicker emissions IEC 61000-3-3	Complies	

Table 3: Electromagnetic immunity

ELECTROMAGNETIC IMMUNITY			
The COOLFLOW Irrigation Pump is intended for use in the electromagnetic environment specified below. The customer or the user of the COOLFLOW Irrigation Pump should assure that it is used in such an environment.			
Immunity test	IEC 60601 test level	Compliance level	Electromagnetic environment - guidance
Electrostatic discharge (ESD) IEC 61000-4-2	±6 kV contact ±8 kV air	±6 kV contact ±8 kV air	Floors should be wood, concrete or ceramic tile. If floors are covered with synthetic material, the relative humidity should be at least 30 %.
Electrical fast transient/ burst IEC 61000-4-4	±2 kV for power supply lines	±2 kV for power supply lines	Mains power quality should be that of a typical commercial or hospital environment.
Surge IEC 61000-4-5	±1 kV differential mode ±2 kV common mode	±1 kV differential mode ±2 kV common mode	Mains power quality should be that of a typical commercial or hospital environment.
Voltage dips, short interruptions and voltage variations on power supply input lines IEC 61000-4-11	<5 % U_T (>95 % dip in U_T) for 0.5 cycle 40 % U_T (60 % dip in U_T) for 5 cycles 70 % U_T (30 % dip in U_T) for 25 cycles <5 % U_T (>95 % dip in U_T) for 5 sec	<5 % U_T (>95 % dip in U_T) for 0.5 cycle 40 % U_T (60 % dip in U_T) for 5 cycles 70 % U_T (30 % dip in U_T) for 25 cycles <5 % U_T (>95 % dip in U_T) for 5 sec	Mains power quality should be that of a typical commercial or hospital environment. If the user of the COOLFLOW Irrigation Pump requires continued operation during power mains interruptions, it is recommended that the COOLFLOW Irrigation Pump be powered from an uninterruptible power supply. Note that a 5 second removal of power, as tested, results in the device shutting down and requires user intervention to restart. There was no interruption of operation for other tests.
Power frequency (50/60 Hz) magnetic field IEC 61000-4-8	3 A/m	3 A/m	Power frequency magnetic fields should be at levels characteristic of a typical location in a typical commercial or hospital environment.
NOTE: U_T is the a.c. mains voltage prior to application of the test level. The COOLFLOW Irrigation Pump was tested at 100 and 230 VAC.			

Table 4: Electromagnetic immunity

ELECTROMAGNETIC IMMUNITY			
The COOLFLOW Irrigation Pump is intended for use in the electromagnetic environment specified below. The customer or the user of the COOLFLOW Irrigation Pump should assure that it is used in such an environment.			
Immunity test	IEC 60601 test level	Compliance level	Electromagnetic environment - guidance
<p>Conducted RF IEC 61000-4-6</p> <p>Radiated RF IEC 61000-4-3</p>	<p>3 Vrms 150 kHz to 80 MHz</p> <p>3 V/m 80 MHz to 2.5 GHz</p>	<p>3 V</p> <p>3 V/m</p>	<p>Portable and mobile RF communications equipment should be used no closer to any part of the COOLFLOW Irrigation Pump, including cables, than the recommended separation distance calculated from the equation applicable to the frequency of the transmitter.</p> <p>Recommended separation distance</p> <p>$d = 1.17 \sqrt{P}$ 150 kHz to 80 MHz</p> <p>$d = 1.17 \sqrt{P}$ 80 MHz to 800 MHz</p> <p>$d = 2.33 \sqrt{P}$ 800 MHz to 2.5 GHz</p> <p>where P is the maximum output power rating of the transmitter in watts (W) according to the transmitter manufacturer and d is the recommended separation distance in meters (m).</p> <p>Field strengths from fixed RF transmitters, as determined by an electromagnetic site survey,^a should be less than the compliance level in each frequency range.^b</p> <p>Interference may occur in the vicinity of equipment marked with the following symbol:</p> <div style="text-align: center;">  </div>
<p>NOTE 1: At 80 MHz and 800 MHz, the higher frequency range applies.</p> <p>NOTE 2: These guidelines may not apply in all situations. Electromagnetic propagation is affected by absorption and reflection from structures, objects and people.</p>			

^a Field strengths from fixed transmitters, such as base stations for radio (cellular/cordless) telephones and land mobile radios, amateur radio, AM and FM radio broadcast and TV broadcast cannot be predicted theoretically with accuracy. To assess the electromagnetic environment due to fixed RF transmitters, an electromagnetic site survey should be considered. If the measured field strength in the location in which the COOLFLOW Irrigation Pump is used exceeds the applicable RF compliance level above, the COOLFLOW Irrigation Pump should be observed to verify normal operation. If abnormal performance is observed, additional measures may be necessary, such as reorienting or relocating the COOLFLOW Irrigation Pump.

^b Over the frequency range 150 kHz to 80 MHz, field strengths should be less than 3 V/m.

Table 5: Recommended separation distances between portable and mobile RF communications equipment and the COOLFLOW Irrigation Pump

RECOMMENDED SEPARATION DISTANCES BETWEEN PORTABLE AND MOBILE RF COMMUNICATIONS EQUIPMENT AND THE COOLFLOW IRRIGATION PUMP			
The COOLFLOW Irrigation Pump is intended for use in an electromagnetic environment in which radiated RF disturbances are controlled. The customer or the user of the COOLFLOW Irrigation Pump can help prevent electromagnetic interference by maintaining a minimum distance between portable and mobile RF communications equipment (transmitters) and the COOLFLOW Irrigation Pump as recommended below, according to the maximum output power of the communications equipment.			
Rated maximum output power of transmitter (W)	Separation distance according to frequency of transmitter (m)		
	150 kHz to 80 MHz $d = 1.17 \sqrt{P}$	80 MHz to 800 MHz $d = 1.17 \sqrt{P}$	800 MHz to 2.5 GHz $d = 2.33 \sqrt{P}$
0.01	0.12	0.12	0.23
0.1	0.37	0.37	0.74
1	1.17	1.17	2.33
10	3.69	3.69	7.38
100	11.67	11.67	23.33
For transmitters rated at a maximum output power not listed above, the recommended separation distance d in meters (m) can be estimated using the equation applicable to the frequency of the transmitter, where P is the maximum output power rating of the transmitter in watts (W) according to the transmitter manufacturer.			
NOTE 1: At 80 MHz and 800 MHz, the separation distance for the higher frequency range applies.			
NOTE 2: These guidelines may not apply in all situations. Electromagnetic propagation is affected by absorption and reflection from structures, objects and people.			

Please note the following when installing and operating the COOLFLOW Irrigation Pump.

- There are special precautions regarding EMC when installing and servicing medical equipment. Be sure the COOLFLOW Irrigation Pump is installed and put into service according to the EMC information provided.
- Portable and mobile RF communication equipment can adversely affect medical devices. Be sure to keep RF communication devices away from the COOLFLOW Irrigation Pump at least as recommended in table 5.

Warning

The COOLFLOW Irrigation Pump should not be used adjacent to or stacked with other equipment. If adjacent or stacked use is necessary, observe the COOLFLOW Irrigation Pump to verify normal operation in the configuration in which it will be used.

9. ACCESSORIES

Foot Pedal (optional)

Biosense Webster

Catalog No. S7005 (U.S.)

Catalog No. 39D03X
(Europe)

Administration Set

Biosense Webster
COOLFLOW™ Tubing Set

Catalog No. CFT001
(U.S. & Europe)

10. LIMITED WARRANTY & LIMITATION OF LIABILITY

BIOSENSE WEBSTER INC. PROVIDES A LIMITED ONE-YEAR WARRANTY ON THIS PRODUCT FOR REPAIR OF THE PUMP IN THE EVENT THAT A REPAIR IS NECESSARY AS A RESULT OF A DEFECT IN MATERIALS OR WORKMANSHIP. REPAIRS MUST ONLY BE PERFORMED BY THE MANUFACTURER OR AN AUTHORIZED REPRESENTATIVE OF THE MANUFACTURER. THIS LIMITED ONE-YEAR WARRANTY PERIOD BEGINS ON THE DATE OF DELIVERY. THERE ARE NO WARRANTIES WHICH EXTEND BEYOND THE DESCRIPTION ON THE FACE HEREOF.

EXCEPT FOR THE LIMITED ONE-YEAR WARRANTY DESCRIBED ABOVE, THERE IS NO EXPRESS OR IMPLIED WARRANTY, INCLUDING WITHOUT LIMITATION ANY IMPLIED WARRANTY OF MERCHANTABILITY OR FITNESS FOR A PARTICULAR PURPOSE, ON THE PRODUCT(S) DESCRIBED HEREIN. UNDER NO CIRCUMSTANCES SHALL BIOSENSE WEBSTER, INC., OR ITS AFFILIATED COMPANIES, BE LIABLE FOR ANY SPECIAL, DIRECT, INCIDENTAL, CONSEQUENTIAL, OR OTHER DAMAGES OTHER THAN AS EXPRESSLY PROVIDED BY SPECIFIC LAW.

WITHOUT LIMITING THE FOREGOING, BIOSENSE WEBSTER, INC., OR ITS AFFILIATED COMPANIES, SHALL NOT BE LIABLE FOR ANY SPECIAL, DIRECT, INCIDENTAL, CONSEQUENTIAL, OR OTHER DAMAGES ARISING OUT OF THE REUSE OF ANY PRODUCT(S) LABELED FOR SINGLE USE OR WHERE REUSE IS PROHIBITED BY APPLICABLE LAW.

Descriptions and specifications appearing in Biosense Webster printed matter, including this publication, are informational only and meant solely to generally describe the product at the time of manufacture and are not made or given as a warranty of the prescribed product in any way.